

1. Preface of installation

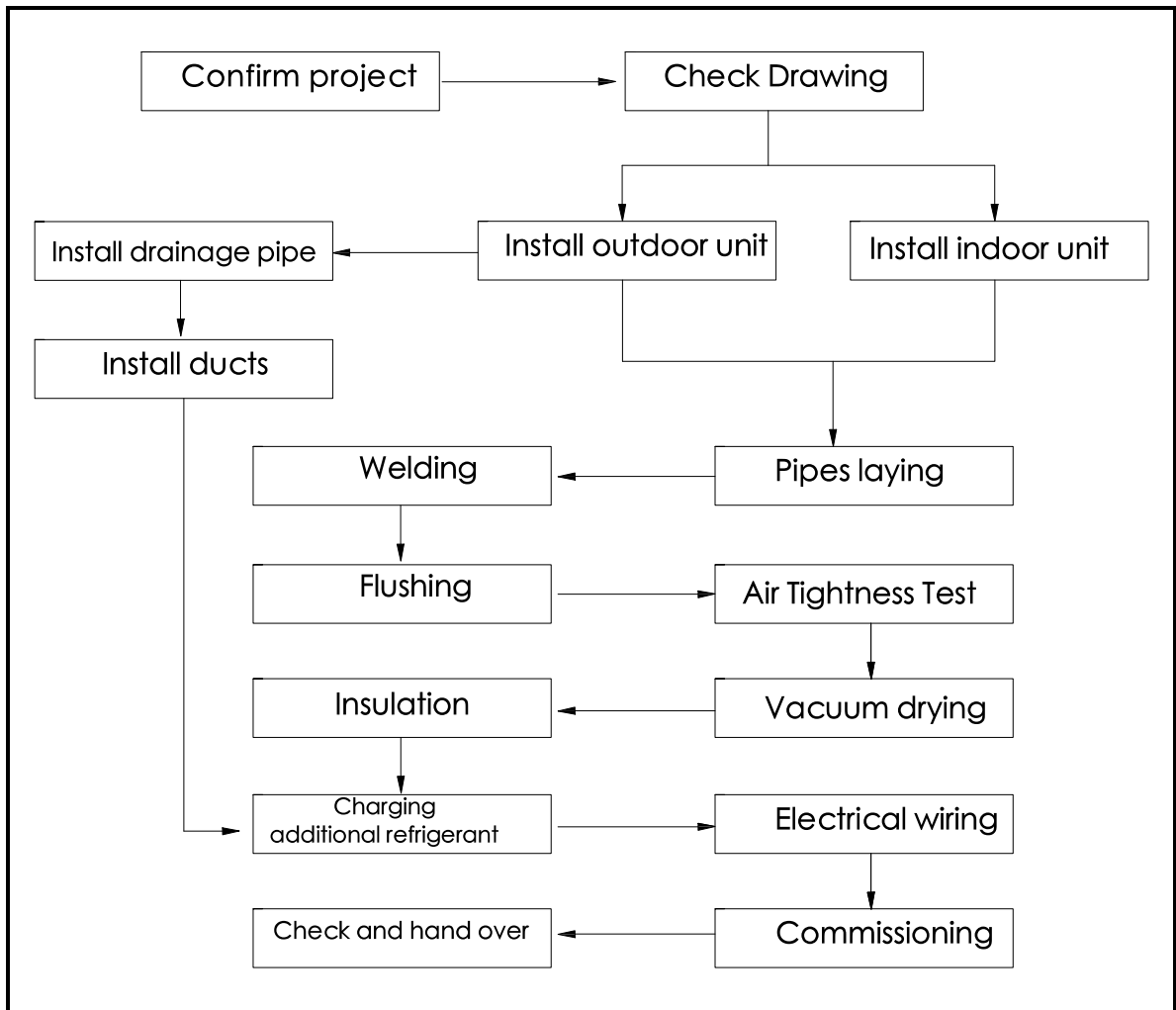

⚠ Caution

- ✧ The proper design and installation is a critical element of ARV system, installation of piping and electrical works must be carried out by ***suitably qualified, certified professionals*** and in accordance with all applicable legislation.
- ✧ In this service manual, the term “applicable legislation” refers to all national, local and other laws, standard, codes, rules, regulations and other legislation that apply in a given situation.

2. Installation of Outdoor Unit

2.1 Installation Location and Foundation

1. Ensure that the outdoor unit is **installed in a dry, well-ventilated place**.
2. Ensure that the **noise and exhaust ventilation** of the outdoor unit **do not affect the neighbors** of the property owner or any surrounding ventilation.
3. Ensure that the outdoor unit is **installed in a cool place** without direct sunlight exposure or direct radiation of a high-temp heat source.
4. The **outdoor unit** should **be installed as close as possible to the indoor unit**.
5. The installation location must be **far from waste and oil mist**.
6. The **foundation should be strong enough** to support the outdoor unit.

2.2 Pre tools

Tape measure	Spanner	Electric hammer
		
Screw driver	Nut gasket	Level meter
		

2.3 Maintenance and Ventilation Space

2.3.1 Ensure necessary installation and maintenance space.

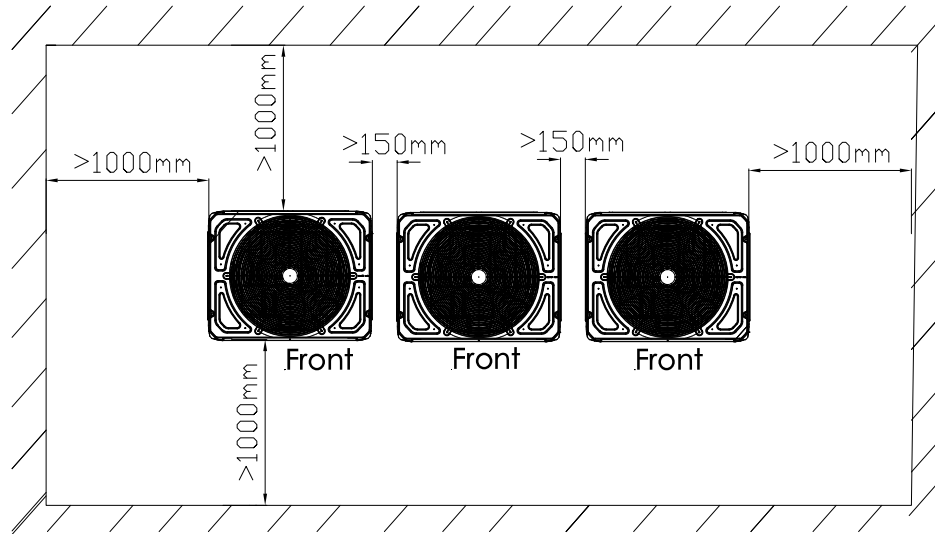

2.3.2 If there are **two rows of outdoor units**, we **suggest face to face installation** for easy maintenance, and avoid air short circuit.

2.3.3 If miscellaneous articles are piled around the outdoor unit, it should be **at least 1000mm higher** than the top of outdoor unit. Otherwise, a mechanical discharge device must be added to improve the ventilation.

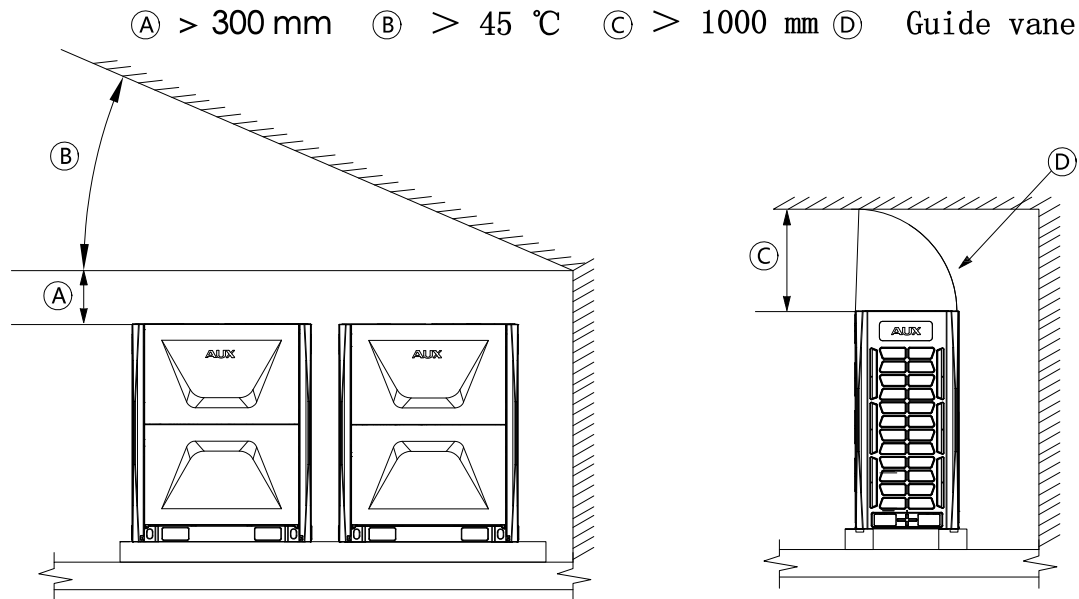

2.4 Installation of Outdoor Unit

2.4.1 Tighten outdoor unit on mounting support with **M10** bolt and nut, and keep it horizontal. The bolt should have a proper length of 20mm more than base surface.

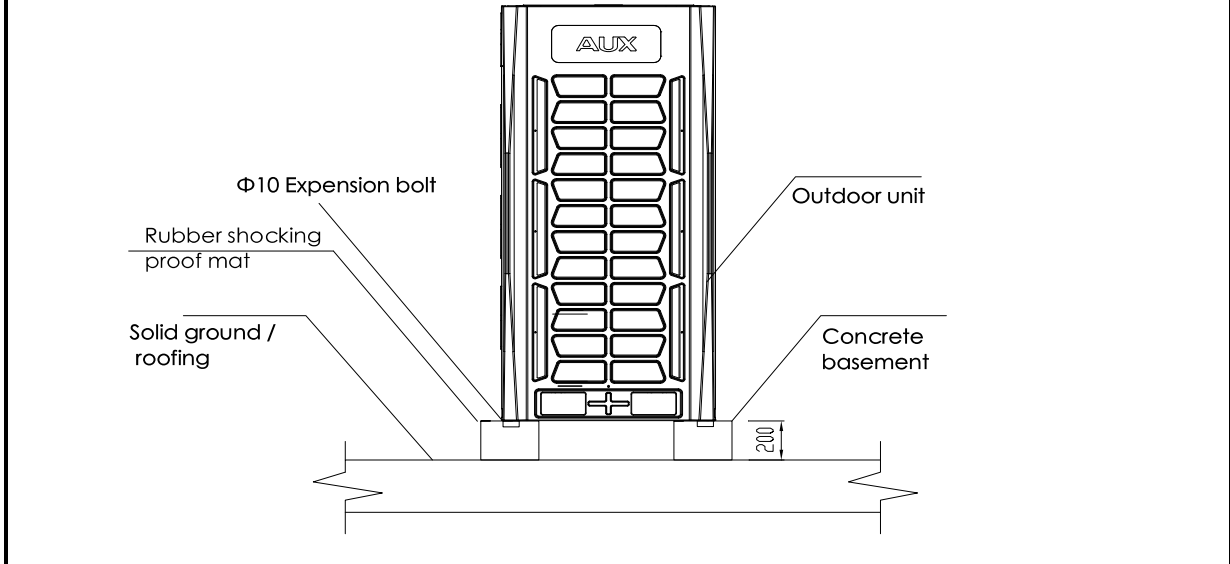

2.4.2 If the system has more than two outdoor units. The **largest capacity** unit should **be set as the master unit**, while the **others should be set as slave units**, as shown in the following example.

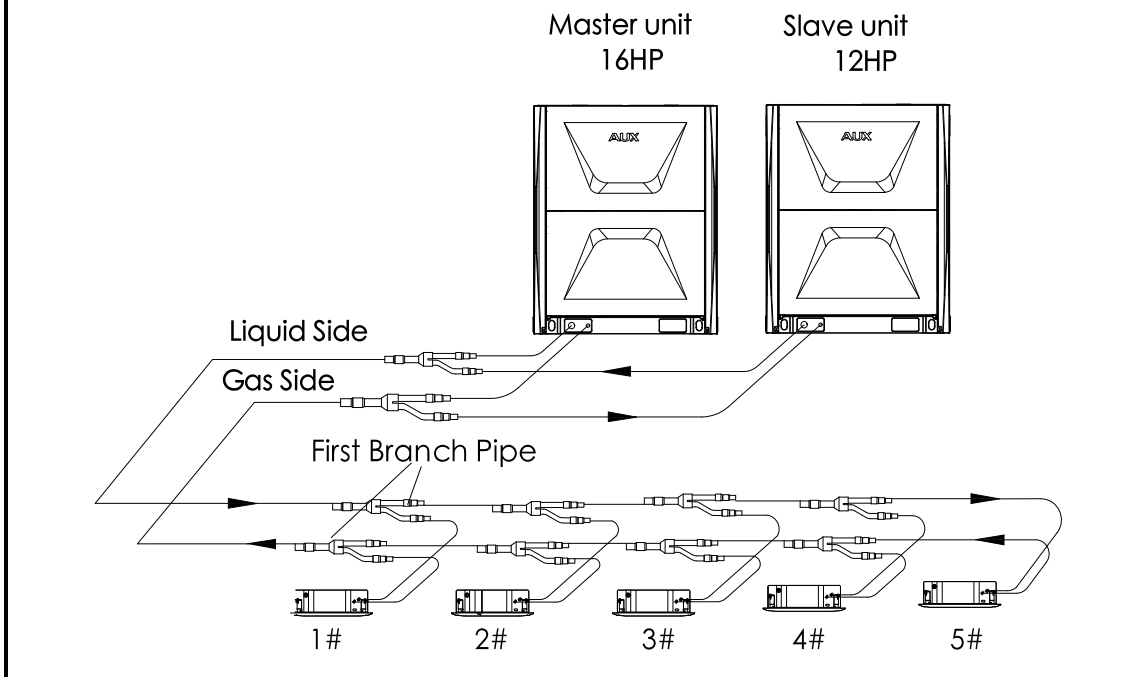

2.4.3 The installation space for a fixed bolt, please refer to the following drawing.

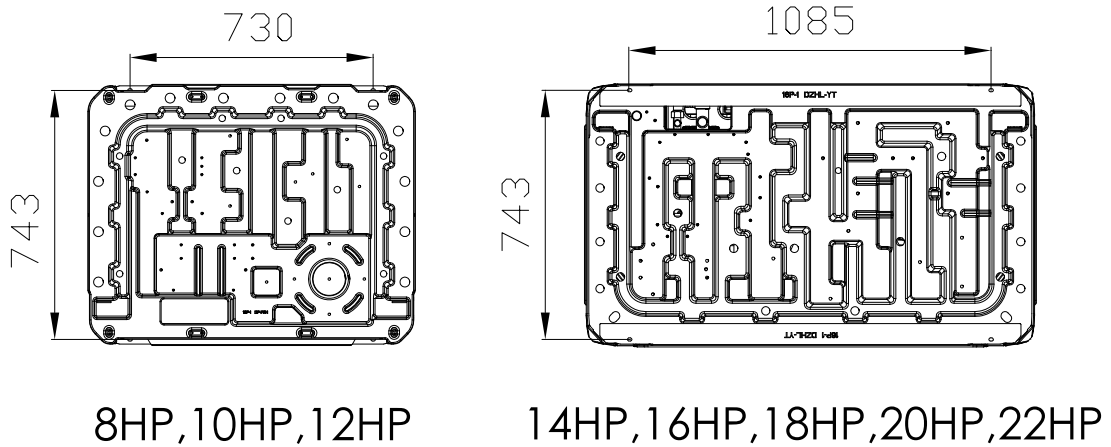

2.4.4 The foundation can be made of **channel steel or concrete**. **Reserve** the space for **discharging** the condensate **water** from outdoor units.

2.4.5 Install drainage channels to ensure condensed **water flow out** smoothly.

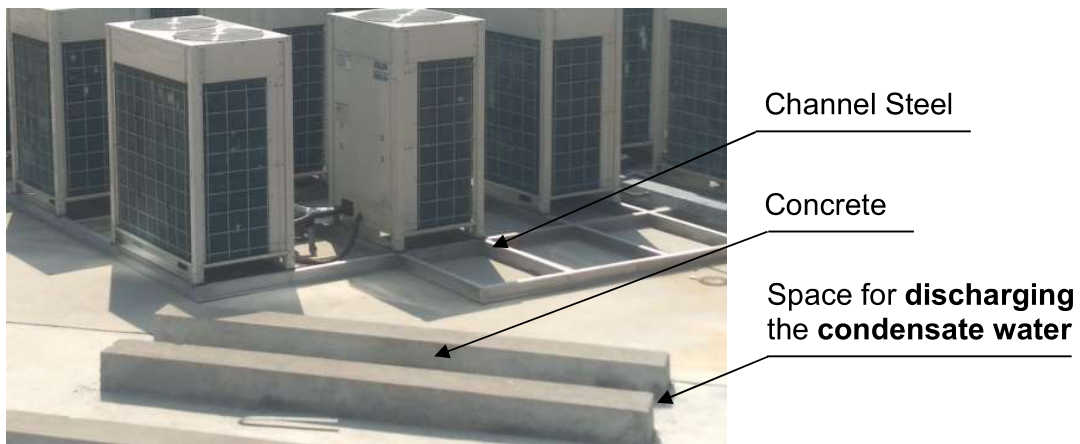

2.4.6 **Don't** use **four-square base** to support outdoor unit.





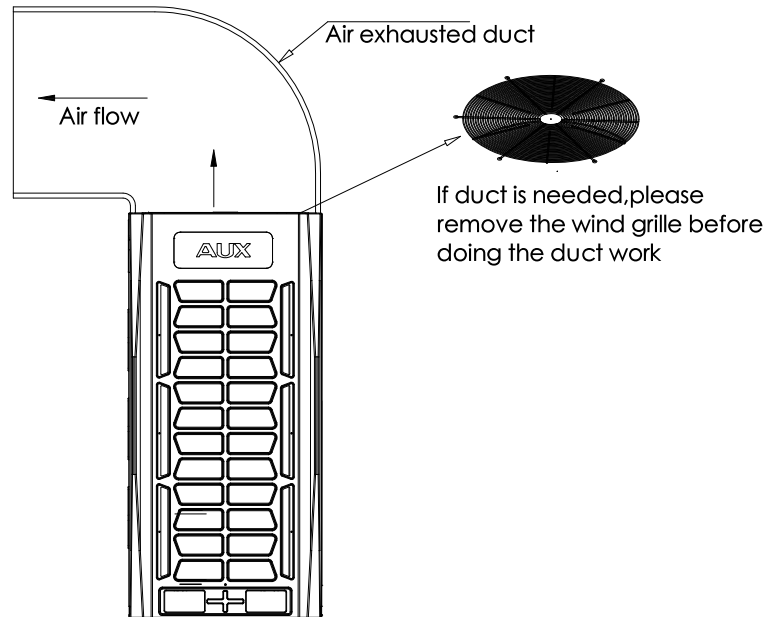



2.4.7 **Rubber anti-vibration pads** are necessary to avoid **vibration**.

2.4.8 If the outdoor unit need side air flow outlet by a **duct**, it is necessary to **remove** out the wind **grille**.



3. Pipes Laying

3.1 Pre tools

Tube expander	Spanner	Expander
		
Screw driver	Electric hammer	Pipe bender
		
Mounting bracket hanger	Hoop	Expansive bolt
		

3.2 Selection of copper pipe

3.2.1 Please use **seamless red copper pipe**.

3.2.2 **Specification** of refrigerant pipe should be selected according to **unit requirement**

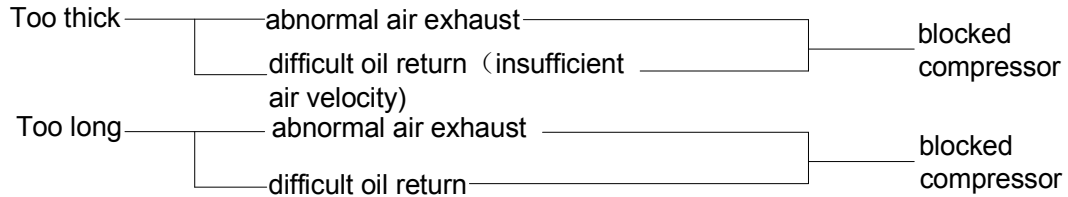

※ Thickness of copper tube

Specifications		Thickness (mm)	Weight / length	
inch	mm		1m =* Kg	1Kg=* m
1/4	Φ 6.35	0.8	0.124	8.06
3/8	Φ 9.52	0.8	0.195	5.12
1/2	Φ 12.7	0.9	0.297	3.36
5/8	Φ 15.88	1.0	0.416	2.4
3/4	Φ 19.05	1.0	0.505	1.98
7/8	Φ 22.22	1.2	0.706	1.41
1	Φ 25.4	1.2	0.813	1.23
	Φ 28.6	1.2	0.92	1.08
	Φ 31.8	1.2	1.11	0.9
	Φ 34.9	1.3	1.223	0.817
	Φ 38.1	1.4	1.438	0.695
	Φ 41.3	1.5	1.671	0.598
	Φ 44.5	1.5	1.823	0.554

3.2.3 If **pipes** will be **stored** for a **long time**, the pipes should be **charged** into **0.2~0.5MPa N2** and the **nozzle** should be **sealed** by welding.



3.2.4 **Don't let dust** such as concrete fragment, sand and copper slag ingress **into the system**;



3.2.5 **Don't install pipe while raining to prevent water ingress**; blocking capillary or expansion valve, generating acid Iron/copper erosion due to refrigerant hydrolysis, generating foreign matter crystal (cage compounds) due to reaction of refrigeration oil

3.3 Accessory bag

Accessory bag in outdoor unit

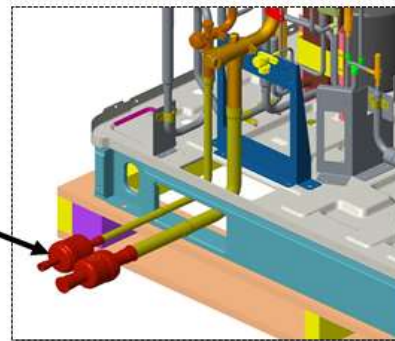

3.4 Bending of copper tube

3.4.1 **Do not** right angle **bending many times in a short distance**

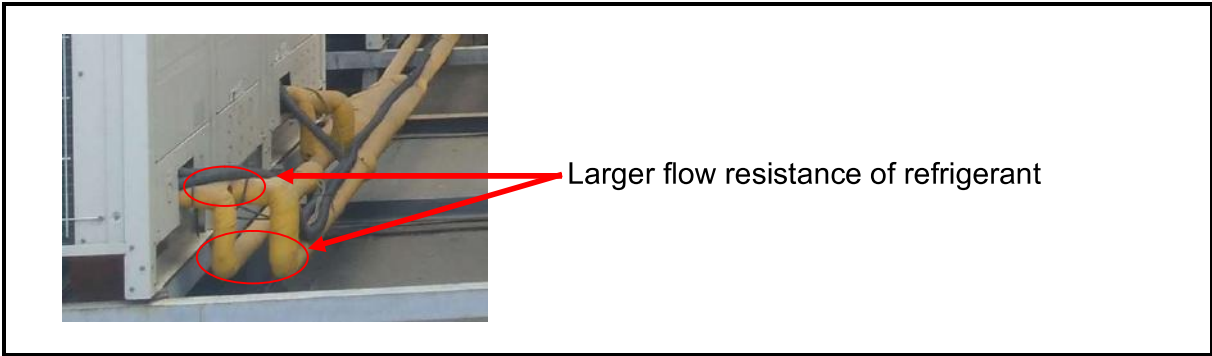

3.4.2 **Pipe bender must be used** for pipe bending. The curvature can't be too small, otherwise the pipe may be bent and shrunken, affecting refrigerant flow;

3.4.3 **Don't repeat bending** and unbending operation over three times on the same position of pipe (because pipe will be hardened in this way).



3.5 Flaring of copper tube

3.5.1 The **burr** of the copper tube **should be removed** before the copper tube is expanded

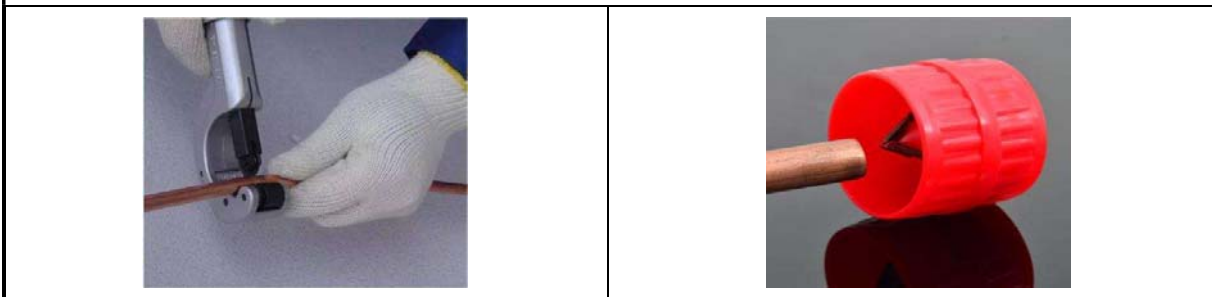

3.5.2 It is required to expand the inside diameter at connection area with **Tube expander**

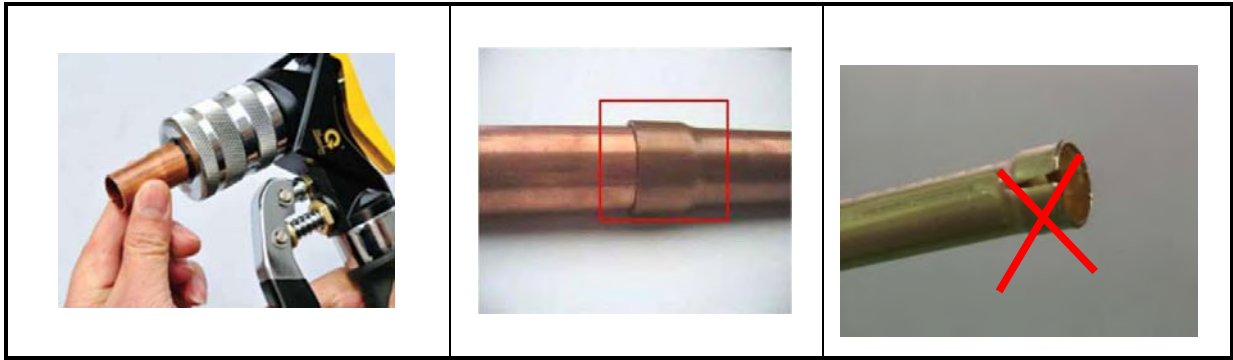

3.5.3 The copper pipe connected to the indoor units needs to be expanded by **Expander**

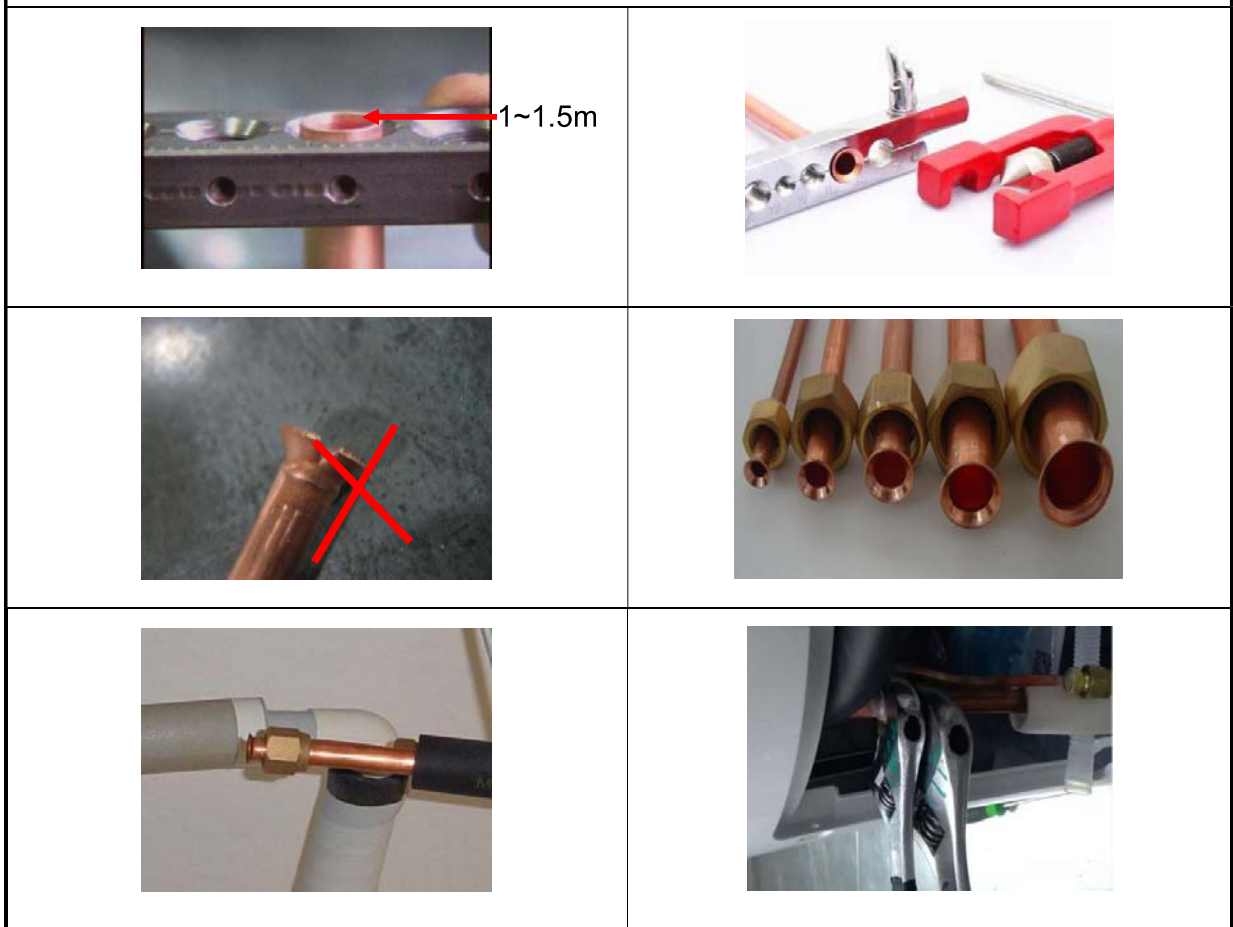

Flare pipe with **Expander** as per the dimensions of flaring opening in the following table.

Diameter of pipe	Tightening torque	Machining dimension of	Shape of flaring	Apply oil
------------------	-------------------	------------------------	------------------	-----------

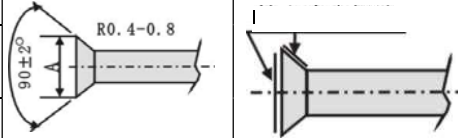
1/4in(φ6.35mm)	15-19 (N·m)	8.8-9.1mm	
3/8in(φ9.52mm)	35-40 (N·m)	12.8-13.2mm	
1/2in(φ12.7mm)	50-60 (N·m)	16.2-16.6mm	
5/8in(φ15.88mm)	68-80 (N·m)	19.2-19.6mm	
3/4in(φ19.05mm)	100-120 (N·m)	23.6-24mm	

3.6 Separation Tube (branch joint)

3.6.1 The **branch** joint must be installed **horizontally** and the lean **angel** should be $\leq 15^\circ$ to avoid refrigerant distribution unbalance.

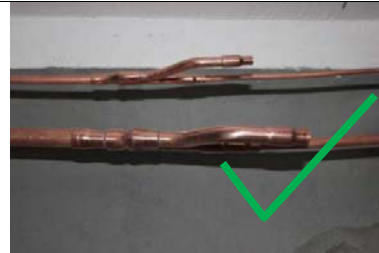
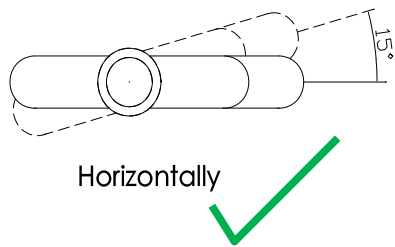

3.6.2 To ensure the refrigerant distribution is balance, pipe length which between two branch joints $\geq 1000\text{mm}$, the straight pipe length after the branch pipe $\geq 500\text{m}$

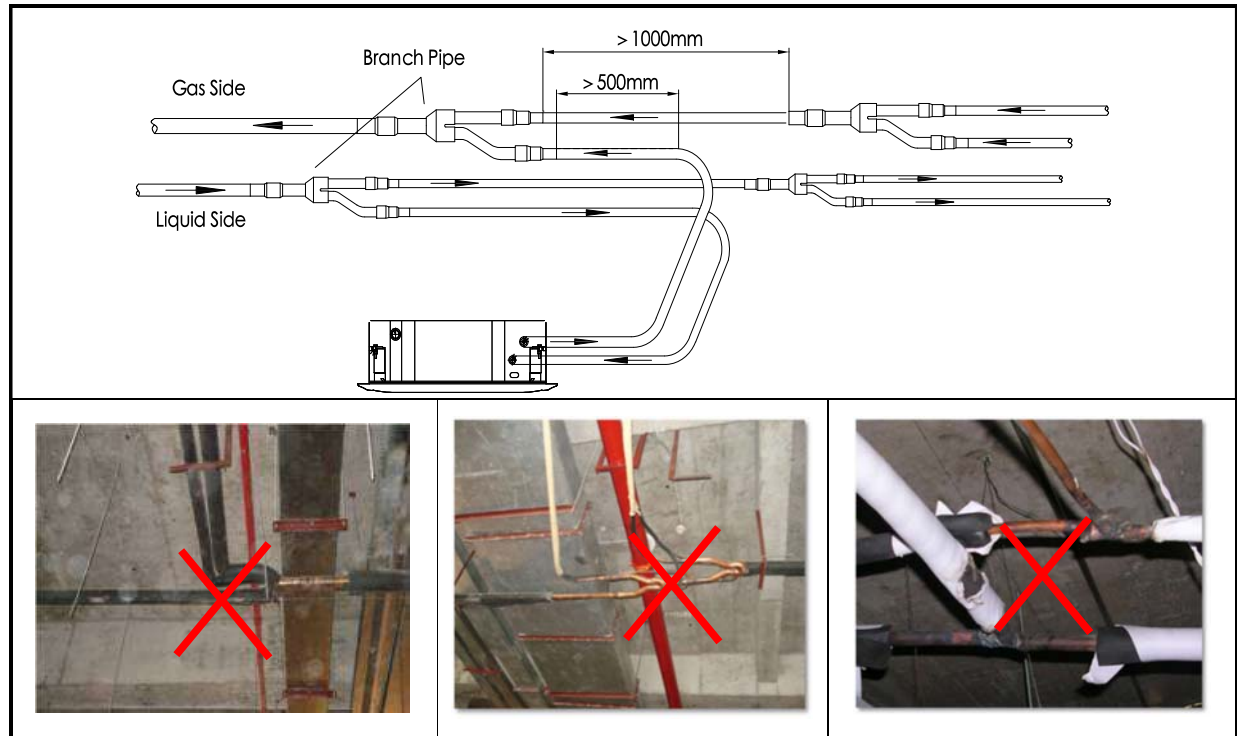

3.7 Oil Trap

When the Vertical **height** between indoor and outdoor units more than **8 or 10 meters**, ensure the Refrigeration **oil return to compressor** smoothly, the **oil trap is necessary**

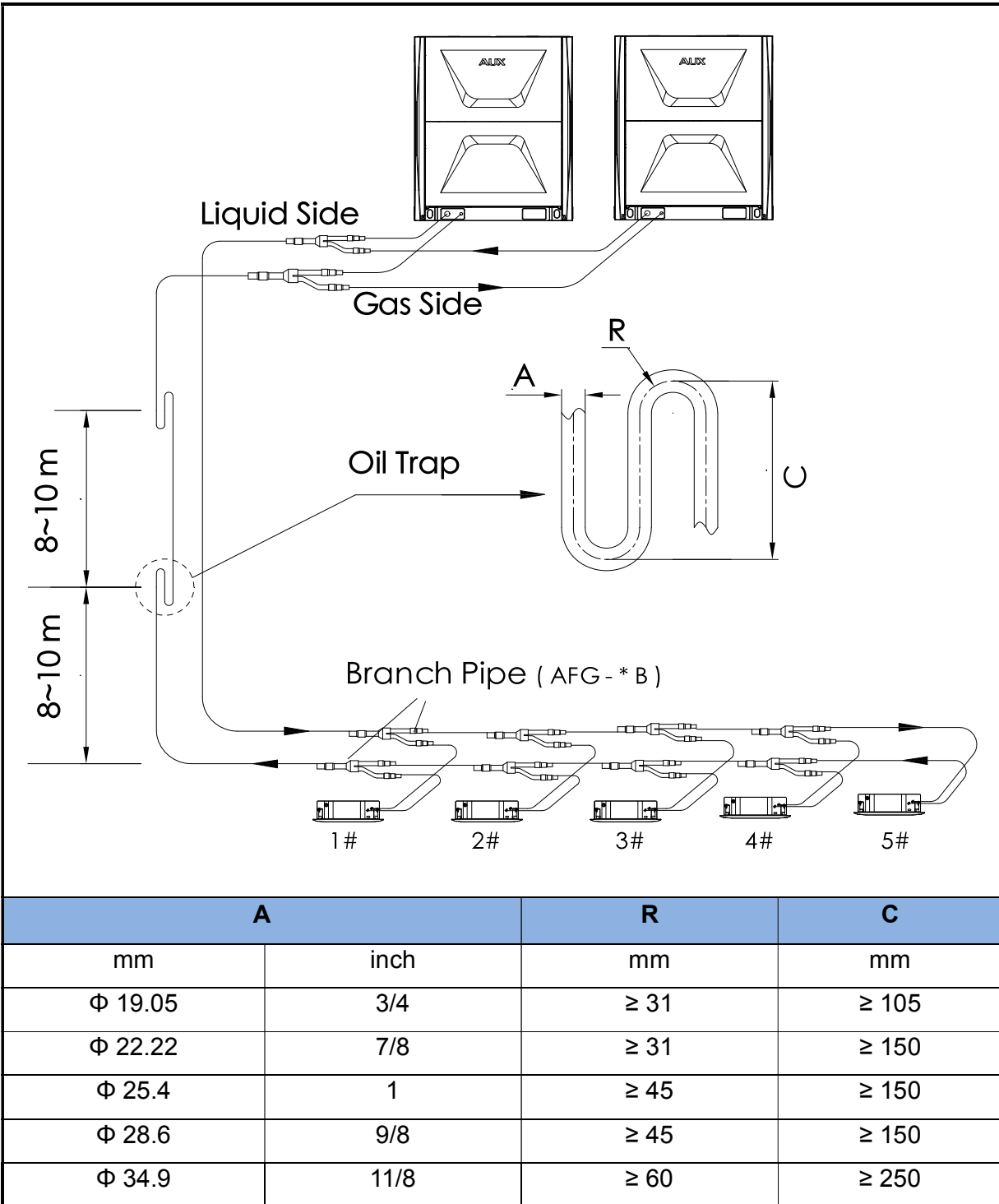





3.8 Pipeline fixing

Refrigerant pipe should be fixed, when running, refrigerant pipe will sway, expand or shrink, if unfixed, load will concentrate on certain part, result fracture of refrigerant pipe. The pipe should be fixed **every 1~2m**.



4. Welding

4.1 Pre tools

Nitrogen cylinder	Nitrogen pressure regulating valve	Nitrogen pressure gauge
		
Welding device	Connection hose	
		

4.2 Flushing

Before connection use nitrogen (The pressure of the nitrogen is **0.5 MPa**) or air to **remove dust** and **moisture** inside pipe.

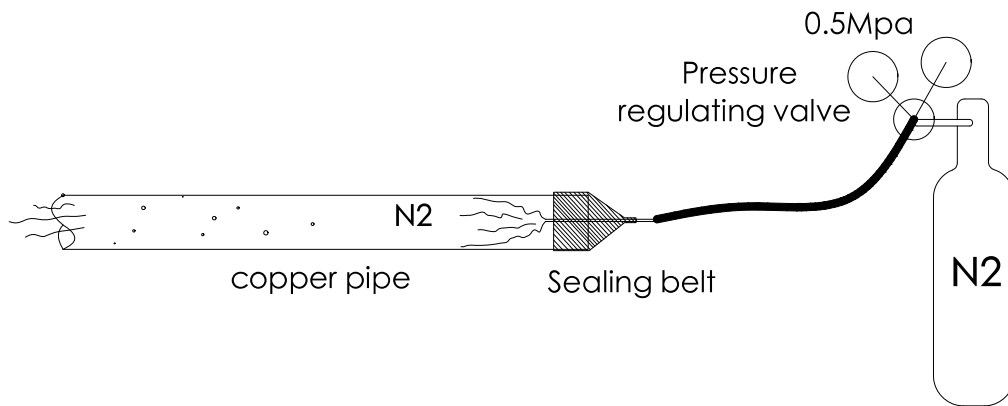

4.3 Fill nitrogen and welding

4.3.1 Ensure to fill nitrogen (The pressure of the nitrogen is **0.02 MPa**) for protection when welding.

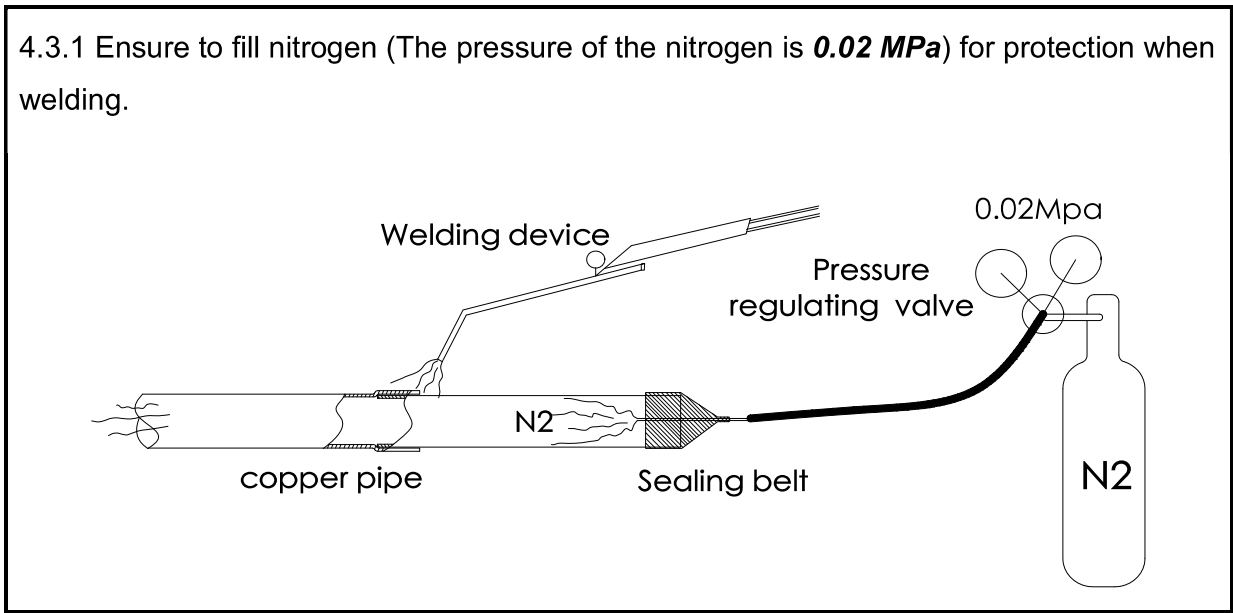

4.3.2 It's necessary to **fill nitrogen to prevent** oxidation layer (**Cu₂O**) formed in copper pipe when welding, otherwise substantial oxidation layers will cause blockage of capillary tube or expansion valve, abnormal discharge temperature, poor cooling or heating performance.

Charge N2 to the pipes



NO N2 to the pipes

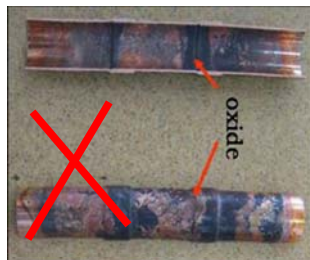

- Cause blockage of EXV*
- Cause Compressor wear*
- Poor cooling/ heating performance*

4.3.3 If permitted, it's recommended to use **less indoor units and shorter pipeline**

5. Gas Tightness Test

5.1 Purpose and Steps

To confirm whether there is leakage in pipe by using nitrogen, and the steps are as follows

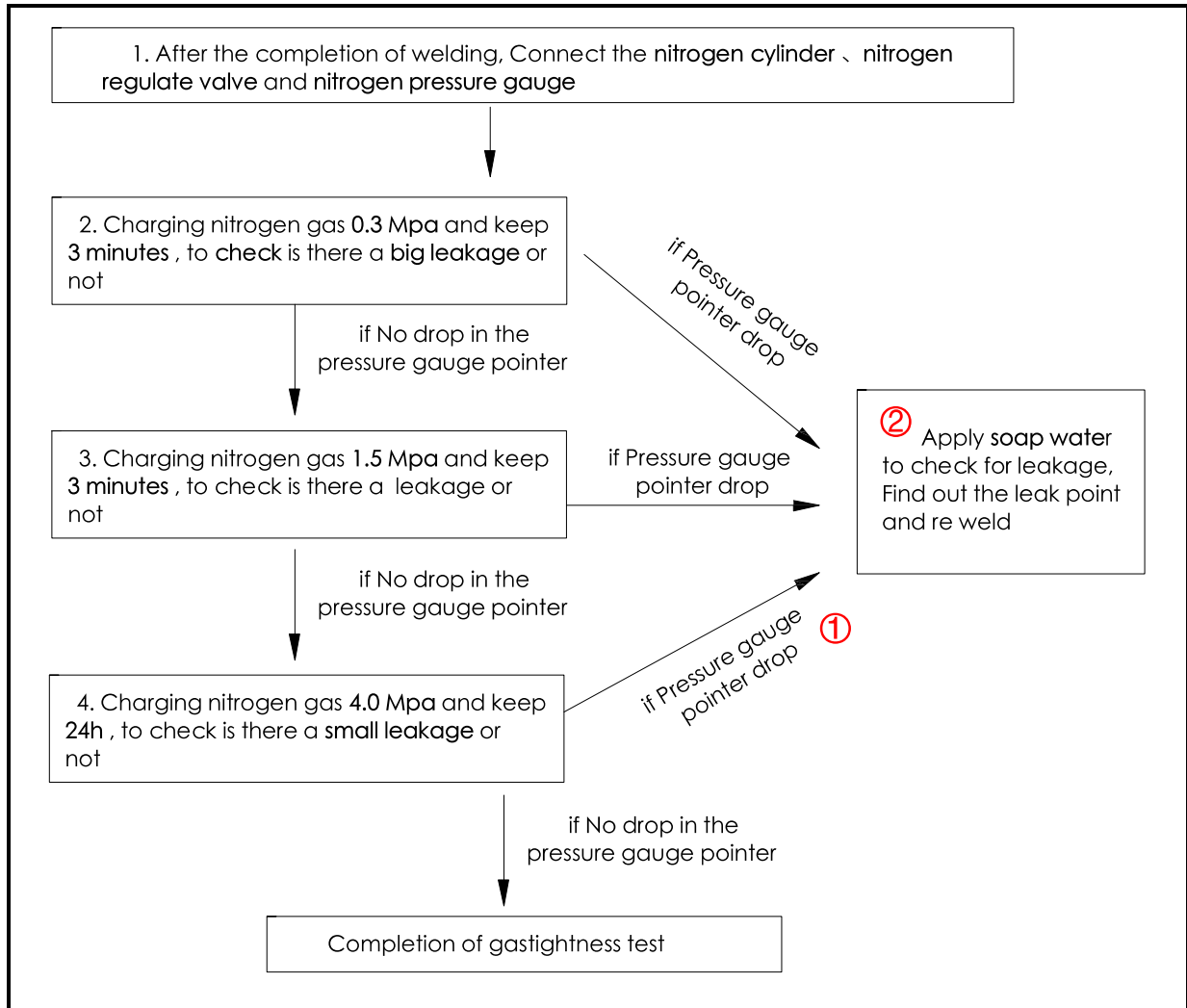

① Observe pressure drops

It's necessary to correct if pressurized temperature is different from observed ambient temperature with difference of **0.01MPa/1 °C**.

Correction value = (Pressurized temperature - observed temperature) x 0.01

Example:

Pressure is 4.0 MPa and temperature is 25°C in case of pressurization.







After 24 hours, if the pressure is 3.95MPa and temperature is 20°C, it is deemed qualified.

② Check leakage point.

If there is pressure drop but leakage point can't be found in pressure test:

1. Discharge nitrogen until the pressure is **0.3MPa**.
2. Charge R410a refrigerant to **0.5MPa** (namely the mixed state of nitrogen and refrigerant).
3. Check with halogen lamp, butane gas (petroleum gas) detector and electric detector.
4. If leakage point can't be found, recheck by continuously pressurize up to **2.8MPa**. (maximum pressure is 4.0MPa)

5.2 Pre Test tool

nitrogen cylinder	Nitrogen pressure regulating valve	Nitrogen pressure gauge
		
Soap water (Use of leakage)	Welding device (Use of leakage)	Connection hose
		

5.3 Caution

There is no power for indoor unit’s EXV before commissioning, so the EXV is closed, the nitrogen gas unable to flow from A to B or B to A

So when charging the nitrogen gas, **it should be charged from the both (liquid & gas) sides**

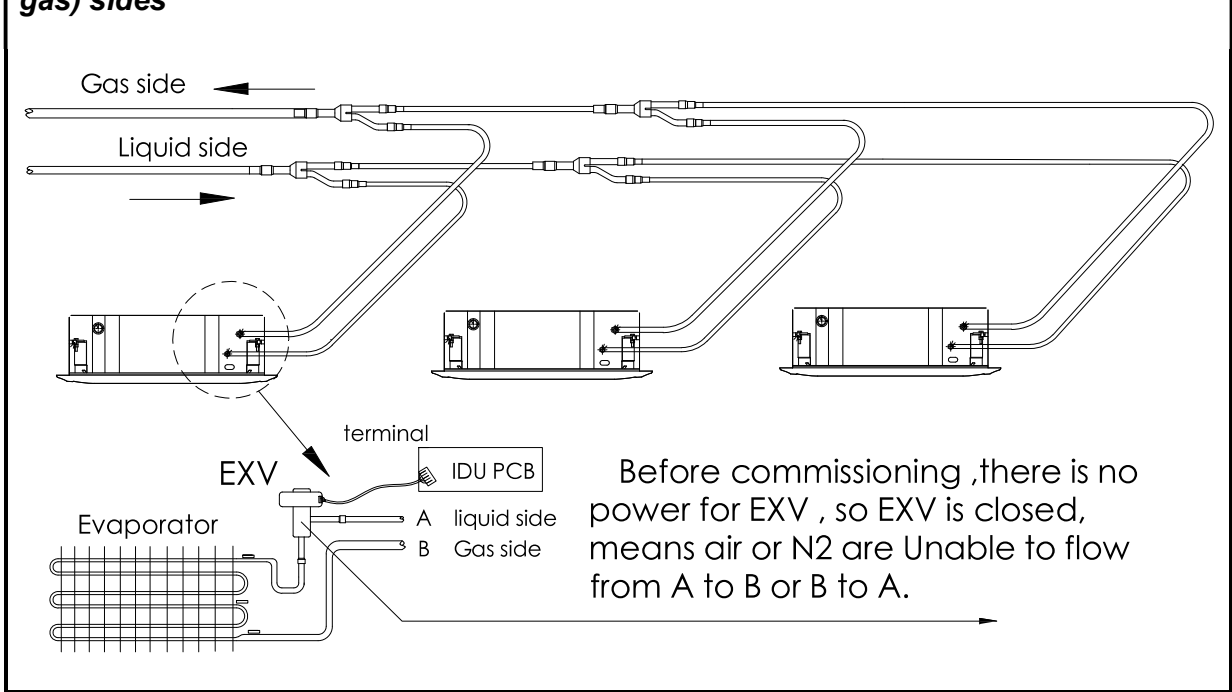

5.4 Schematic diagram

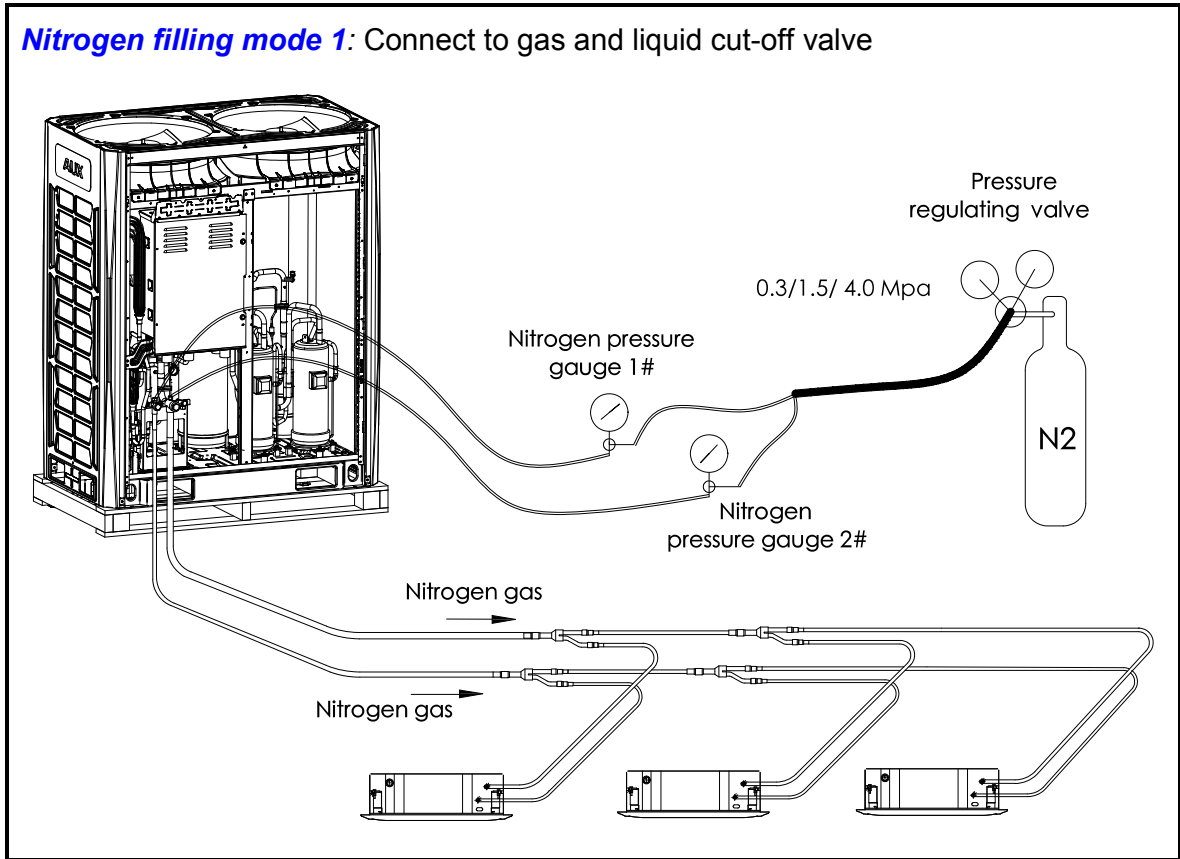

Nitrogen filling mode 2: Connect to main gas & liquid piping

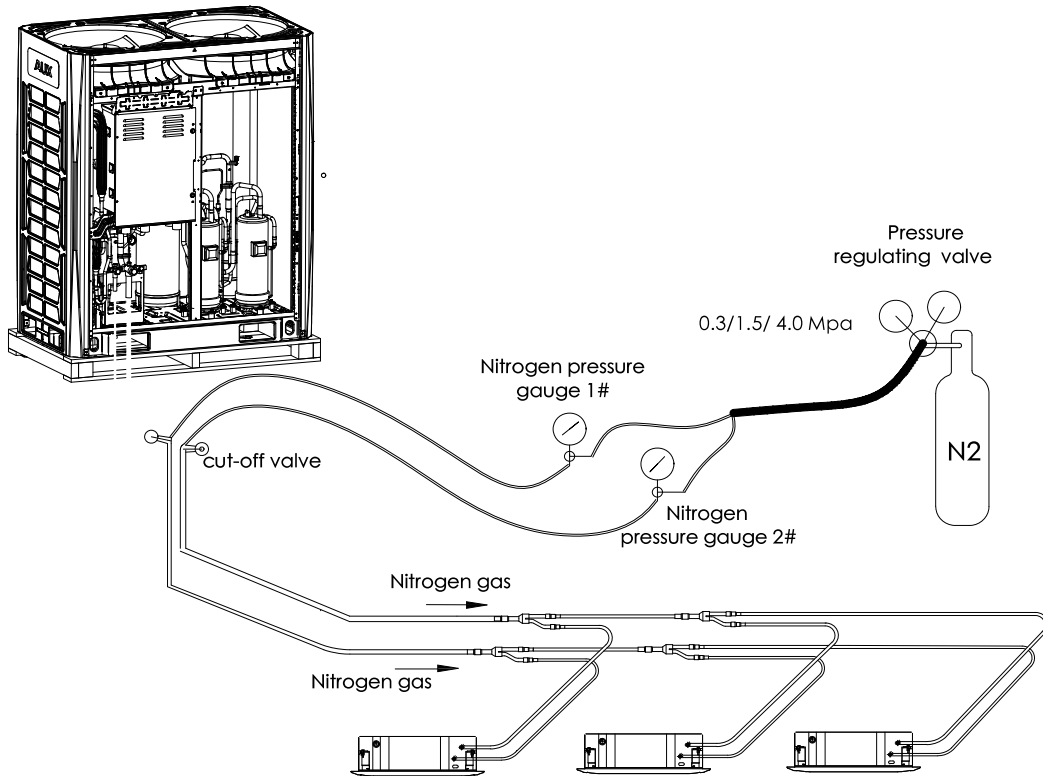

If pressure gauge point drops, apply soap water (*Focus on inspection of welding points, such as 1~8 below*) to check for leakage, Find out the leak point and re weld

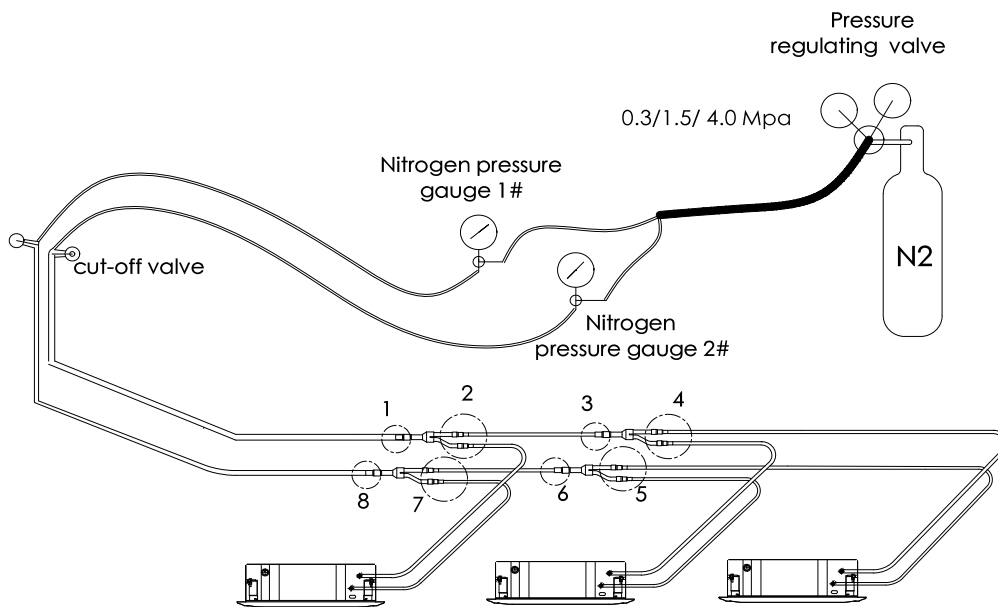

6. Vacuum Drying

6.1 Selection of vacuum pump

1. Vacuuming suction must be less than -14.6PSI (756mmHg).
2. The discharge of vacuum pump is over **4L/s**.
3. The precision of vacuum pump is over 0.001ft.H₂O (0.02mmHg)



Note:

1. Under the normal air pressure, the boiling point of water (steam temperature) *is* **100 °C**, but the pressure in vacuum pump pipe is near vacuum, this makes the boiling point lower to below the outside air temperature, and the water in the pipe is evaporated.
2. After the vacuuming process of R410A refrigerant circulation system is complete, vacuum pump will stop running. As a result of suction in the in the air conditioning system, vacuum pump lubricant will seep back into the system. This situation will also occur if vacuum pump suddenly stops during operation. It will cause different oils mix, leading to system malfunction, therefore it is recommended to use one-way valve to prevent reverse flow of oil in vacuum pump.

Water's boiling point (°C)	Pressure (mmHg)	Vacuum degree (mmHg)
40	55	-705
30	36	-724
26.7	25	-735
24.4	23	-737
22.2	20	-740
20.6	18	-742
17.8	15	-745
15.0	13	-747
11.7	10	-750
7.2	8	-752
0	5	-755

Example: When the ambient temperature is 7.2°C, vacuuming can be carried out under -752mmHg.

6.2 Pre tools

Vacuum pump (4L/s)	vacuum pressure gauge	Connection hose
		

6.3 Schematic diagram

Gas and liquid stop valve must be closed, 1~3 valves should be opened
 Vacuum pump with **one-way valve** to **prevent pump oil** from flowing backward while the vacuum pump is stopped

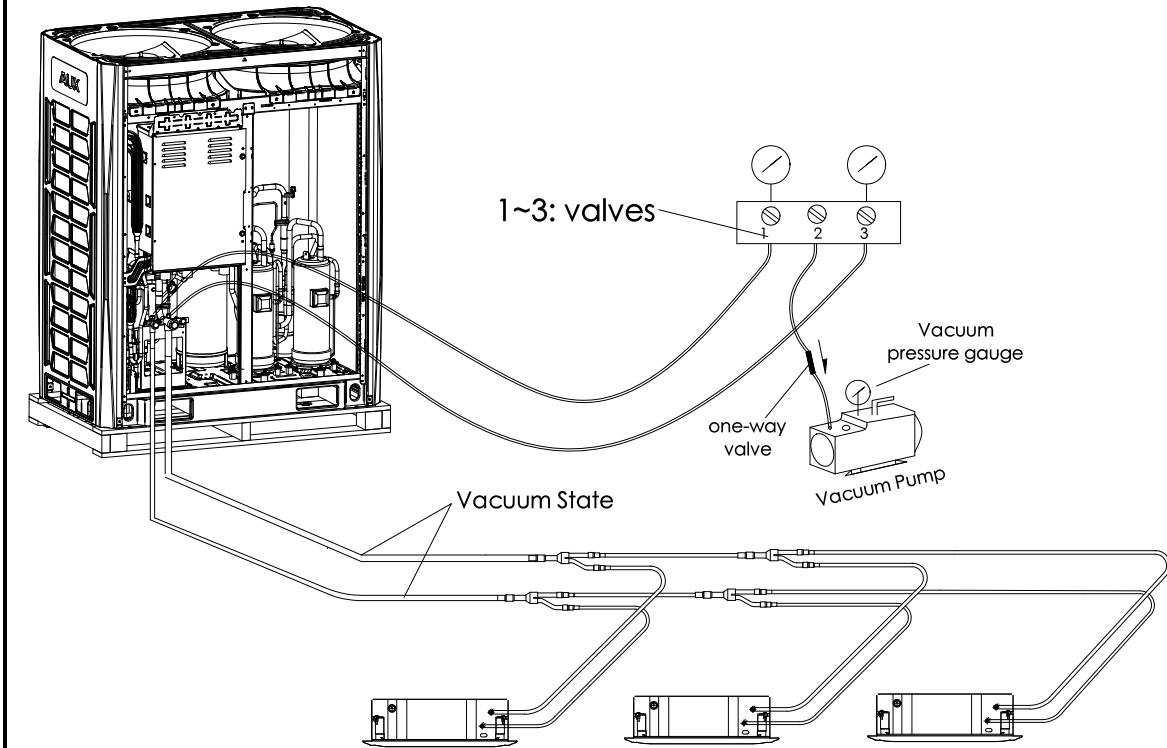

6.5 Vacuum drying

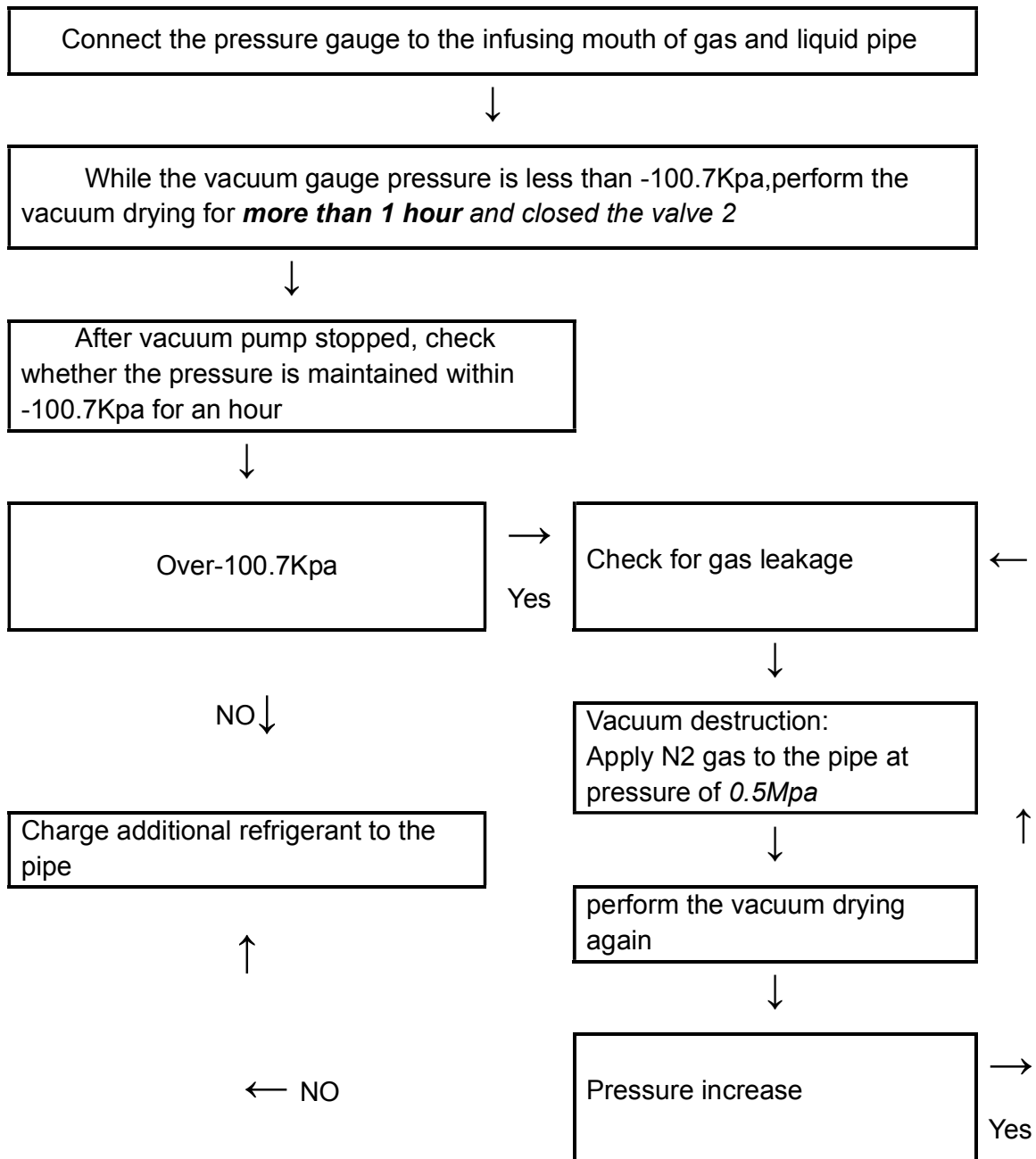

7. Insulation

7.1 Purpose of Insulation

- Prevent condensate water adhere to the gas pipe
- Protect people from hurt of high temp.
- Avoid energy loss

7.2 Pre tools

Rubber and plastic insulation casing	Cutting knife	Air conditioning bandage
		

7.3 Caution

7.3.1 The insulation of liquid pipe and gas pipe must be separate

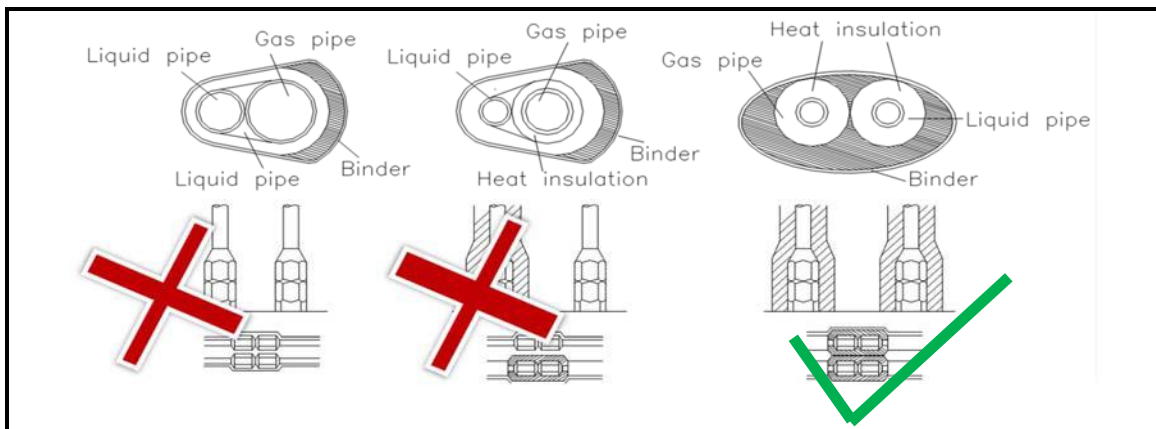

7.3.2 The insulation work must be done to every part of refrigerant pipes



7.3.3 Insulation material

Pipe diameter	Thickness
Φ6.4~15.9mm	≥15mm
Φ15.9~38.1mm	≥20mm
Φ38.1~54.1mm	≥25mm

7.3.4 Thermal insulation wrapping of pipe

Thermal insulation materials should be used for drainage pipe and refrigerant pipe to **prevent condensation or water leakage**.

Note:

- ✧ Wrap refrigerant pipe with thermal insulation materials of good insulation performance ($> 120^{\circ}\text{C}$).
- ✧ Notice for high-humidity environment: the A/C system is verified by condensation conditions test. However, it may subject to dripping if working in high-humidity (condensation temperature $> 23^{\circ}\text{C}$) environment for a long time. In this case, please add the following thermal insulation materials:
- ✧ The thermal insulation materials should be glass fiber thermal insulation materials with 10~20mm thickness.

7.3.5 Sealing of Wall Opening

After installing pipe and drainage pipe, it's necessary to **seal the gap** among wall opening, refrigerant pipe, **drainage** pipe and electric wire with **mortar or putty** to prevent capacity degradation or water leakage caused by rainwater or foreign matter from ingress into room and A/C system.

8. Additional refrigerant





8.1 Calculate refrigerant charge volume

Calculate the required refrigerant volume by the length of liquid pipe → recharge refrigerant.

Pipe size of liquid side (mm)	L1 Φ25.4	L2 Φ22.22	L3 Φ19.05	L4 Φ15.88	L5 Φ12.7	L6 Φ9.52	L7 Φ6.35
Additional refrigerant charge per meter (kg)	0.45	0.34	0.25	0.17	0.11	0.054	0.022

Additional refrigerant charge volume = (L1×0.45)+(L2×0.34)+(L3×0.25)+(L4×0.17)
+ (L5×0.11) + (L6×0.054) + (L7×0.022)

8.2 Pre tools

Vacuum pump (4L/s)	Connection hose	electronic scale
		
R410A		
		

8.3 Schematic diagram

1. 1~4 # valves all are opened
2. 1#, 3#, 4# valves are opened, 2# valve are closed

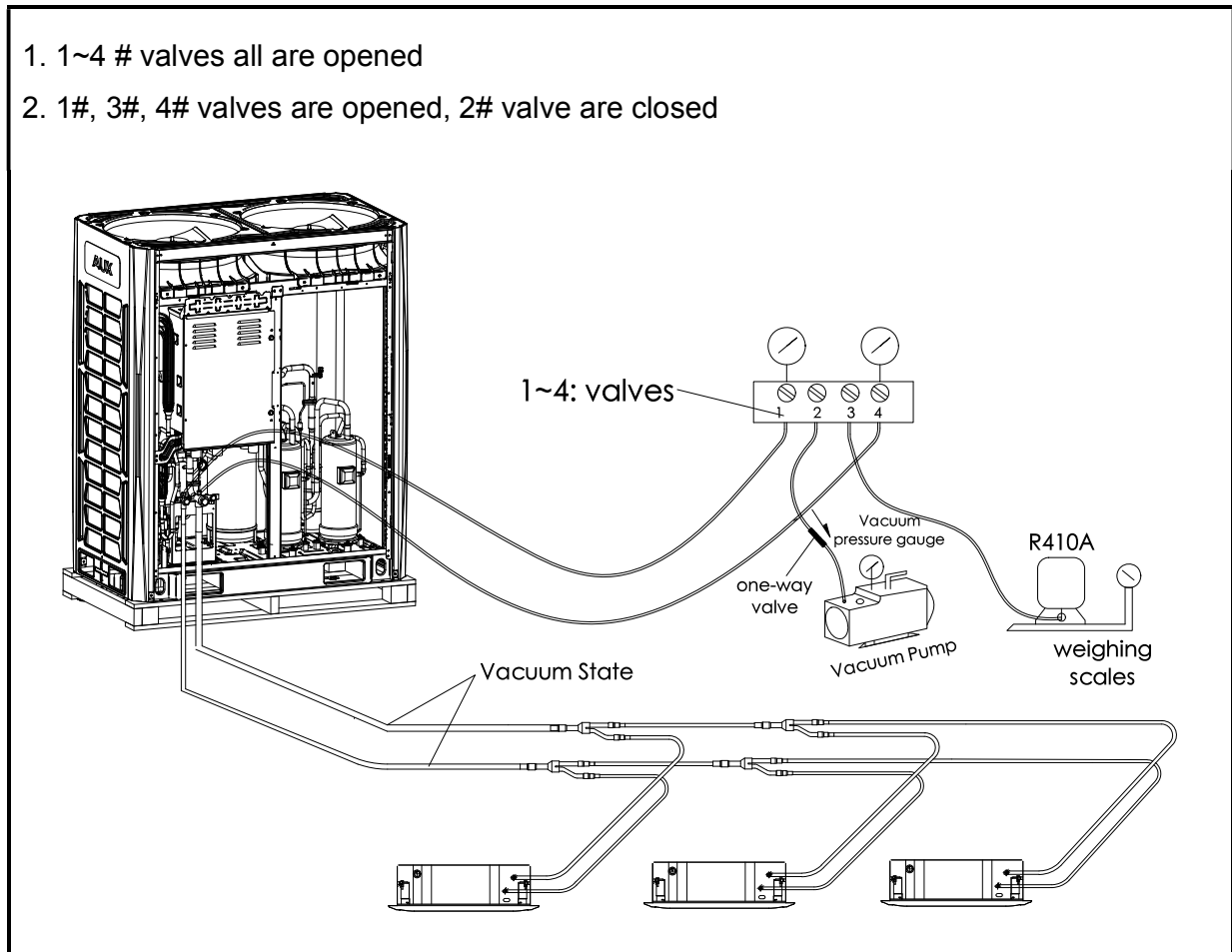

8.4 Steps for recharging refrigerant

1. Make sure **vacuum drying** is qualified before recharging refrigerant.
2. **Calculate the required refrigerant volume** by the diameter and the length of liquid pipe.
3. Use **electronic scale** or fluid infusion apparatus to weigh the recharged refrigerant volume.
4. Use soft pipe to connect refrigerant cylinder, pressure gauge, and examine valve of outdoor unit. And recharge in liquid mode. Before recharging, clear the air in the soft pipe and pressure gauge's pipe.

9. Electrical Wiring

9.1 Wiring Diagram of Indoor Unit and Outdoor Unit

Power line must be properly fixed; Outdoor unit must be grounded;

Each indoor unit must be grounded; Power wire must be thickened when it is overlong.

Wiring Diagram of Modular Outdoor Unit

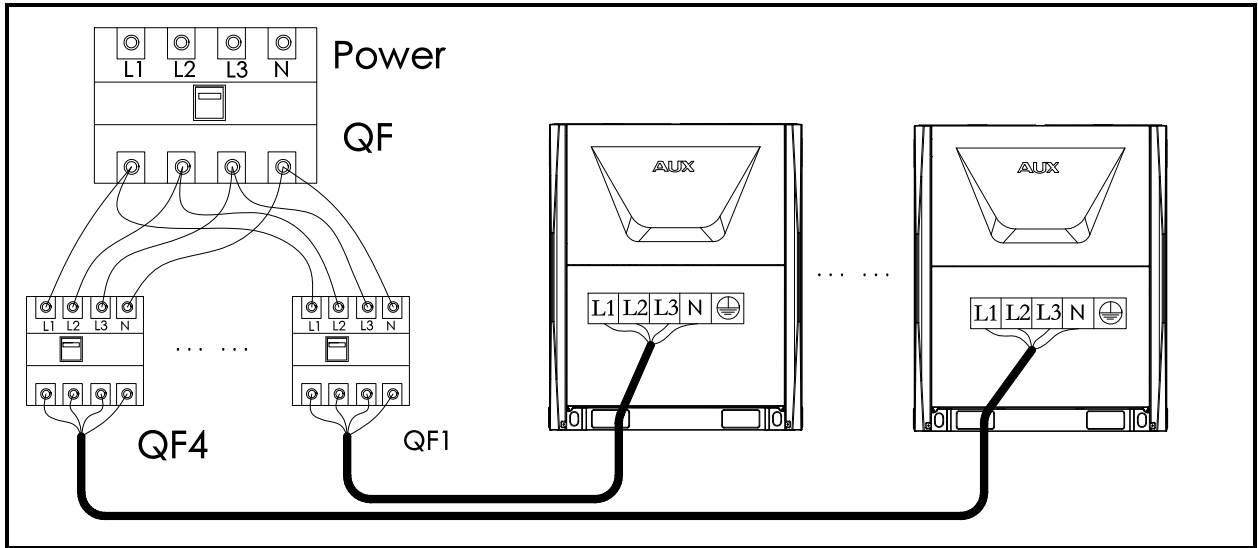

Recommended Specification for Power Line of Outdoor Unit (stand-alone power supply)

Item		Power supply	power line (mm ²)	breaker (A)	leakage current Operate time	ground wire(mm ²)
Unit Type						
Separate power	ARV-H250/SR 1MV	380~415V 3Ph ~ 50/60Hz	4	32	30mA, < 0.1 sec.	4
	ARV-H280/SR 1MV		6	32	30mA, < 0.1 sec.	6
	ARV-H330/SR 1MV		6	40	30mA, < 0.1 sec.	6
	ARV-H400/SR 1MV		6	50	30mA, < 0.1 sec.	6
	ARV-H450/SR 1MV		6	50	30mA, < 0.1 sec.	6
	ARV-H500/SR 1MV		10	63	30mA, < 0.1 sec.	10
	ARV-H560/SR 1MV		10	63	30mA, < 0.1 sec.	10